

Top-class conveyor performance with upgraded SKF Three-barrier solution

Harsh conditions demand tough solutions

Conveyor pulleys with open bearings live a tough life, exposed to dirt and high-pressure washdowns. Ingress of dirt and loss of grease lead to insufficient bearing lubrication and indentations in the bearing raceways. The result is frequent conveyor breakdowns and weekly re-greasing. In 8 out of 10 mining plants, availability is less than 87%.



Key benefits:

3x 
service life

Up to
92% 
conveyor uptime

Up to
90% 
less grease

Up to
99.9%
if not purged



Upgraded SKF Three-barrier solution

The SKF Three-barrier solution has an average lifetime three times longer than an open bearing. The result is fewer conveyor pulley bearing breakdowns and longer maintenance intervals – delivering up to 92% availability and planned maintenance of conveyor pulley can even be timed with lagging replacement.

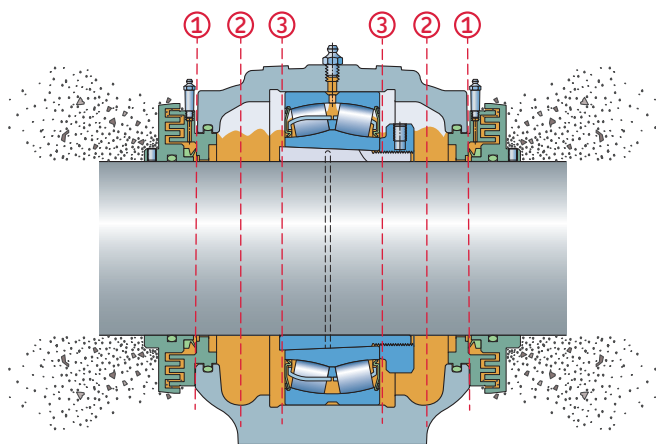

Barrier 1

SMS (SKF Mining Specific) housing with SKF Taconite sealing

Barrier 2

SKF LGGB 2 biodegradable grease

Barrier 3

Sealed SKF Explorer spherical roller bearing

The upgraded SKF Three-barrier solution means re-greasing twice a year instead of once a week, saving up to 90% of the time and cost of greasing (up to 99.9% if not purged) and increasing safety for maintenance workers.

Key features and upgrades

The SKF Three-barrier solution is now updated with an SKF Mining Specification variant housing, using the new SKF Taconite sealing with two rings, one stationary and one rotating, forming a narrow labyrinth between the rings. Bolt-on end covers are another new feature.

The upgraded SKF Three-barrier solution is prepared for vibration measurement, allowing smarter monitoring and preventive maintenance.

Compatible with conventional conveyors

Available in a wide range of sizes and fulfilling all relevant ISO standards, the upgraded SKF Three-barrier solution uses the same sizes for housings and bearings as conventional open bearings. The replacement procedure and lead times are identical.



skf.com

© SKF is a registered trademark of the SKF Group.

© SKF Group 2019

The contents of this publication are the copyright of the publisher and may not be reproduced (even extracts) unless prior written permission is granted. Every care has been taken to ensure the accuracy of the information contained in this publication but no liability can be accepted for any loss or damage whether direct, indirect or consequential arising out of the use of the information contained herein.

PUB 73/S7 18357 EN · March 2019

Certain image(s) used under license from Shutterstock.com.